

CMA TAPPING MACHINES PNEUMATIC - ELECTRONIC - HYDRAULIC



CATALOGO R-2007/1

COMERCIAL DE MAQUINARIA ALZIRA S.L.

Polígono Industrial, 1 • C/ Moliners, 10 • Phone +34 96 240 0800 • Fax +34 96 241 6105

P. O. Box 210 • 46600 **ALZIRA** (Valencia) SPAIN
e-mail: info@cmamachines.com • <http://www.cmamachines.com>

RS SERIES



Standard equipment:

- Air set: regulator, manometer, filter and impermeator.
- Pneumatic motor.
- Fixed mount.
- Quick change chuck for Bilz system collets.
- Air flow: 650 l/min.
- Working pressure: 7 Kgr/cm²

model	capacity	working area	rpm	weight
RS-1.400	M2 - M12	100 - 500	(1) 400	12 Kg.
RS-2.400	M2 - M12	100 - 700	(1) 400	15 Kg.
RS-3.400	M2 - M12	100 - 900	(1) 400	18 Kg.
Chuckl n° 1 / ø19				

RN SERIES



RN-12.400



RNR-20.400

Standard equipment:

- Air set: regulator, manometer, filter and impermeator.
- Pneumatic motor.
- Fixed mount.
- Tap lubricator system.
- Quick change chuck for Bilz system collets.
- Air flow: 650 l/min.
- Working pressure: 7 Kgr/cm²
- Working area: 1.800 mm.

model	capacity	chuck	rpm	weight
RN-12.400	M3 - M12	N° 1 - Ø19	(1) 400	25 Kg.
RNM-12.400*	M3 - M12	N° 1 - Ø19	(1) 400	26 Kg.
RNR-20.400	M3 - M24	N° 2 - Ø31	(2) 400/115	26 Kg.
RNRM-20.400*	M3 - M24	N° 2 - Ø31	(2) 400/115	27 Kg.

(1) Available: Motor 600rpm / Capacity M10, Motor 800rpm / Capacity M10 and motor 1000rpm / Capacity M8.

(2) Available: Motor 600rpm / Capacity M20.

* Machines equipped with multiposition head.

RER SERIES



Standard equipment:

- Electronic motor single-phase type Brushless to 220V.
- Electronic tap speed governor (Forward and reverse).
- Automatic depth stop: Depth program from manual screen, stop and automatic reverse.
- Digital readout.
- Fixed mount.
- Tap lubricator system.
- Quick change chuck for Bilz system collets.
- Gear box with two speeds.
- Working area: 1.800 mm.
- **Table with T. Slots 800 x600 (Optional)**

model	capacity	chuck	rpm	weight
RER-24D	M3 - M24	N° 2 - Ø31	500 / 140	32 Kg.
RERM-24D*	M3 - M24	N° 2 - Ø31	500 / 140	35 Kg.

* Machines equipped with multiposition head.

Work in automatic:

Filling on touch screen pitch and depth, machine program automatically number of turns and make following cycle.

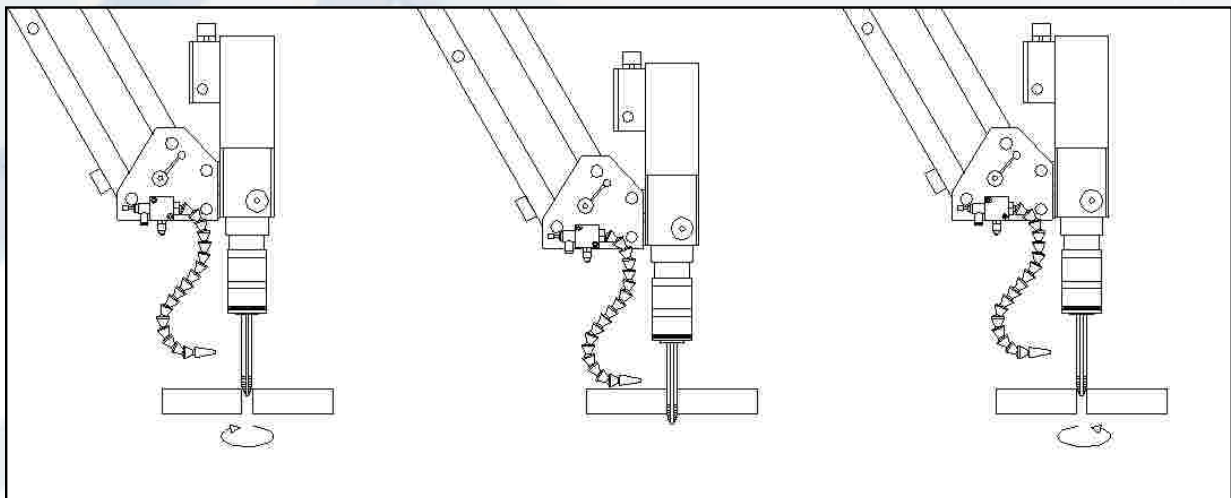

Tapping till depth limit

Stop on depth limit

Forward until extract the tap

RH SERIES



RH-20



RHM-20



RHR-30



RHRM-30

Standard equipment:

- Worktable with T. Form canals of 800 x 600 mm.
 - Hydraulic equipment mounted into the table.
 - Quick change chuck for BILZ system collets.
 - Independent tap speed governors (Forward and reverse).
 - Tap lubricator system.
 - Working area: 1.800 mm.
- Special standard accessories on RHR-45 & RHRM-45 models:
 - Digital tachometer.
 - Inverter.
 - Independent electronic tap speed governors (Forward and reverse).
 - Working area: 2.200 mm.
 - Special standard accessories on RHR-60 & RHRM-60 models:
 - Same special standard accessories than RHR-45 & RHRM-45 models
 - Coolant pump & tank.
 - Worktable with T. Form canals of 1000 x 680 mm.

HYDRAULIC TAPPING MACHINES



RHR-45D



RHRM-45D



RHR-60D



RHRM-60D

model	capacity	chuck	rpm	weight
RH-20 RHM-20*	M3 - M24	N° 2 - Ø31	325	280 Kg. 285 Kg.
RHR-30 RHRM-30*	M4 - M30	N° 2 - Ø31	500/140	285 Kg. 290 Kg.
RHR-45 D RHRM-45 D*	M4 - M45	N° 3 - Ø48	475/105	320 Kg. 330 Kg.
RHR-60 D RHRM-60 D*	M6 - M60	N° 4 - Ø60	240/45	380 Kg. 400 Kg.

(D)- Machine equipped with inverter and digital readout - standard on models M45 and M60, optional in the other hydraulic machines.

* Machines equipped with multiposition head.

GH SERIES



GH models mount the same articulated arms and hydraulic groups as our RH models but without any table, mounting the hydraulic group in a little moving box and the arm in your own table.

These models are perfect for working in bigger pieces using a magnetic base mount.

Their reduced shipping price make them attractive for outer European countries.

model	capacity	chuck	rpm	weight
GH-20 GHM-20*	M3 - M24	N° 2 - Ø31	325	170 Kg. 175 Kg.
GHR-30 GHRM-30*	M4 - M30	N° 2 - Ø31	500/140	175 Kg. 180 Kg.
GHR-45 D GHRM-45 D*	M4 - M45	N° 3 - Ø48	475/105	210 Kg. 220 Kg.
GHR-60 D GHRM-60 D*	M6 - M60	N° 4 - Ø60	240/45	260 Kg. 280 Kg.

(D)- Machine equipped with inverter and digital readout - Standard on models M45 and M60, optional in the other hydraulic machines.

* Machines equipped with multiposition head.

• Quick change toolholders:



Tap collets & adapters



Threading die collets



Drill chuck adapters

• Automatic depth stop:



Pneumatics



Hydraulics

• Tables 800x600 mm:



Pneumatics



Pneumatics and electronics



Lateral 600x350

• Other clamps:



Magnetic clamp "mini"



Magnetic clamp B1



Magnetic clamp B2



C-clamp mount

• Set of castors:



Pneumatics and electronics



Hydraulics



Hydraulics

• Other hydraulic accessories:



Cooler pump & tank



Digital readout



Table 1000x680



COMERCIAL DE MAQUINARIA ALZIRA S.L.

Polígono Industrial nº 1 - C/ Moliners 10 - E46600 Alzira (Valencia) Spain

Tel: +34 96 240 08 00 - Fax: +34 96 241 61 05

e-mail: info@cmamachines.com

www.cmamachines.com